

VRLA Rechargeable Battery

MPL55-12 Handle Type



FEATURES

- Maintenance free(no water topping-up required)
- No free acid(Non-spillable battery)
- Low self-discharge rate,lower than 3% capacity loss per month
- Can be used in any orientation(excluding used inverted)
- The battery is designed with very lower resistance and exceeding high power performance.
- Absorbent Glass Mat technology for efficient gas recombination

APPLICATIONS

- UPS
- Telecom
- Golf-Carts
- Cable TV
- Power station
- Marine



SPECIFICATIONS

Nominal Voltage	12 V
Nominal Capacity	53Ah @ 10 hour rate F.V.(1.75V/cell)
Approx. Weight	17.8Kg(39.2lbs.)
Terminals	B5 (Fitting M6 bolt & nut) I2 is optional
Internal Resistance	≤5mΩ (Fully Charged)
Max. Charge Current	15.9 A
Cold Cranking Amp @ -18°C	480 A
Short Circuit Current	1600 A
Operating Temperature Range	Charge 0°C~50°C(32°F~122°F) Discharge -20°C~60°C(-4°F~140°F) Storage. -20°C~50°C(-4°F~122°F)
Container Material	Standard: PP(UL94 HB) MPL55-12 Optional: Flame Retardant PP(UL94 V-0) MPL55-12FR



MH19884



C4M20310-2474-E-16

- IEC61056-1
- JIS C 8702-1
- GB/T 19639.1

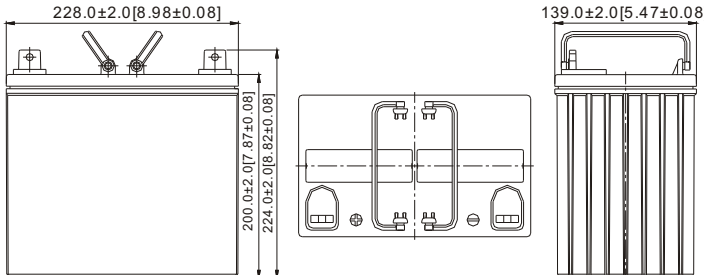
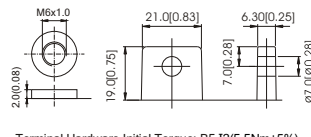
DIMENSION(mm/inch)	OUTER DIMENSIONS	TERMINAL TYPE
<ul style="list-style-type: none"> ■ Length 228±2.0 (8.98±0.08) ■ Width 139±2.0 (5.47±0.08) ■ Container Height 200±2.0 (7.87±0.08) ■ Total Height B5:224±2.0 (8.82±0.08) I2:207±2.0 (8.15±0.08) 		<ul style="list-style-type: none"> ● Terminal I2 ● Terminal B5  <p>Terminal Hardware Initial Torque: B5,I2(5.5Nm±5%)</p>

Constant power discharge characteristics at 25 °C/77 °F Unit: W

F.V. (V/cell)	Discharge Time	5 Min	10 Min	15 Min	20 Min	25 Min	30 Min	40 Min	50 Min	60 Min	90 Min
1.80V		1905	1400	1163	972	843	740	596	500	433	308
1.75V		2135	1501	1230	1009	868	759	608	510	440	313
1.70V		2277	1563	1270	1035	884	771	616	516	445	316
1.65V		2370	1612	1300	1055	898	780	623	521	449	319
1.60V		2440	1644	1320	1070	910	787	630	526	453	321

Constant current discharge characteristics at 25 °C/77 °F Unit: A

F.V. (V/cell)	Discharge Time	5 Min	10 Min	15 Min	20 Min	25 Min	30 Min	40 Min	50 Min	60 Min	90 Min
1.80V		176	123	101	83	71	62	50	42	36.4	25.7
1.75V		193	132	106	87	74	64	51	43	37.0	26.2
1.70V		206	138	110	89	76	65	52	43	37.4	26.5
1.65V		215	142	113	91	77	66	52	44	37.7	26.8
1.60V		222	145	115	92	78	67	53	44	38.0	27.0

All data and artworks shall be changed without prior notice, BB reserves the right to explain and update the information contained hereinto.